

MCSM3M1-025X | DATASHEET

Macro lens for 1.1" sensors, magnification from 0.25x to 1x, C-mount, Scheimpflug adjustment



KEY ADVANTAGES

Precision Scheimpflug mount

Image focus is retained across any tilted plane.

Wide image circle for sensors up to 1.1"

Compatible with any C-mount cameras

The back focal length meets the C-mount standard.

Application flexibility

Supports a wide range of magnification factors and viewing angles.

MCSM3M1-025X is a variable macro lens for sensors up to 1.1" specifically designed for 3D measurement and imaging applications where the object plane is not perpendicular to the optical axis. A precise built-in adjustment mechanism allows the lens to accurately meet the Scheimpflug condition and to image tilted planes in perfect focus.

SPECIFICATIONS

Optical specifications

Magnification range		0.25x - 1x
Image circle	(mm)	17.6
Max sensor size		1.1"
Working distance at 0.1x ¹	(mm)	131.7
Working distance at 1.0x ¹	(mm)	58.4
Focal length	(mm)	32
<i>f</i> / <i>N</i>		5
<i>wf</i> / <i>N</i> at 0.1x ²		6
<i>wf</i> / <i>N</i> at 1.0x ²		10

Mechanical specifications

Mount		C
Max mount tilt	(°)	20
Phase adjustment		Yes
Length ³	(mm)	50.8
Width	(mm)	55.0
Height	(mm)	40.0
Front diameter	(mm)	23
Mass	(g)	163

¹ Working distance: distance between the front end of the mechanics and the object. Set this distance within $\pm 3\%$ of the nominal value for maximum resolution and minimum distortion.

² working *f*/*N*: the real *f*/*N* of a lens in operating conditions.

³ Measured from the front end of the mechanics to the camera flange.

COMPATIBLE PRODUCTS

Full list of compatible products available [here](#).



A wide selection of innovative machine vision components.

MAGNIFICATION AND FIELD OF VIEW FOR 1.1" SENSOR (14.16mm x 10.37mm)

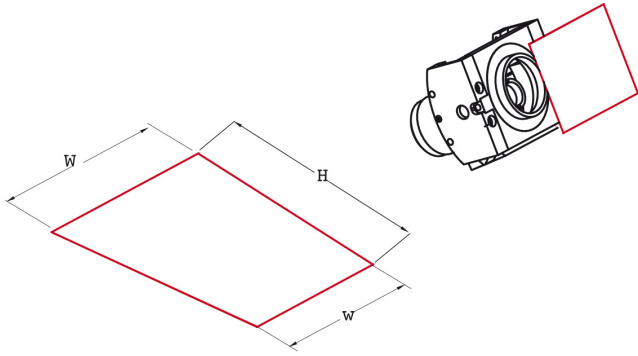

Field of View with detector's long side set horizontal

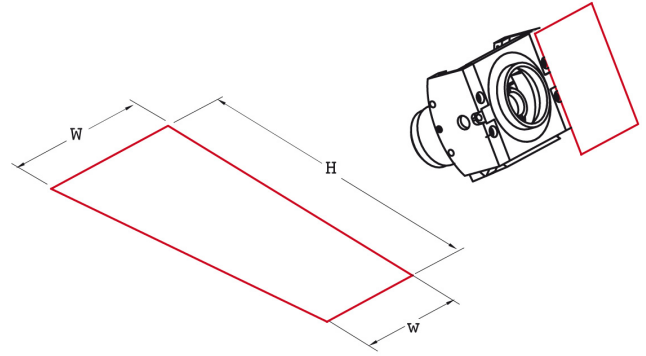

Field of View with detector's long side set vertical

Mag (x)	WD ¹ (mm)	f/N	wf/N ²	Obj Tilt (°)	Img Tilt (°)	Long detector side horizontal			Long detector side vertical		
						w (mm)	W (mm)	H (mm)	w (mm)	W (mm)	H (mm)
1.00	58.4	6	12	0.0	0.0	14.16	14.16	10.37	10.37	10.37	14.16
				5.0	5.0	13.99	14.39	10.39	10.20	10.59	14.20
				10.0	10.0	13.80	14.60	10.40	10.01	10.80	14.20
				15.0	15.0	13.62	14.81	10.40	9.3	11.02	14.23
0.75	62.0	6	10	0.0	0.0	18.88	18.88	13.83	13.83	13.83	18.88
				7.5	5.6	18.52	19.32	13.91	13.46	14.27	19.00
				15.0	11.3	18.15	19.75	14.09	13.10	14.70	19.27
				20.0	15.2	17.90	20.05	14.27	12.86	15.01	19.54
0.50	75.4	6	9	0.0	0.0	28.32	28.32	20.74	20.74	20.74	28.32
				10.0	5.0	27.58	29.17	21.02	20.00	21.60	28.73
				20.0	10.3	26.81	30.08	21.82	19.25	22.54	29.88
				30.0	16.0	26.03	31.14	23.23	18.51	23.65	31.94
0.33	8102.2	6	8	0.0	0.0	42.91	42.91	31.42	31.42	31.42	42.91
				15.0	5.1	40.75	44.41	32.16	29.40	33.07	43.98
				30.0	10.8	38.95	46.77	35.59	27.68	35.55	48.95
				45.0	18.4	36.87	50.16	42.78	25.75	39.33	59.64
0.25	131.7	6	7	0.0	0.0	55.96	55.96	41.56	41.56	41.56	55.96
				15.0	3.8	54.29	59.17	42.91	39.17	44.06	58.70
				30.0	8.2	51.86	62.36	47.80	36.85	47.42	65.75
				45.0	14.0	48.98	67.10	58.34	34.18	52.70	81.41

¹ Working distance: distance between the front end of the mechanics and the object. Set this distance within ±3% of the nominal value for maximum resolution and minimum distortion.

² working f/N: the real f/N of a lens in operating conditions.

MAGNIFICATION 1.00x, OBJECT TILT 0°

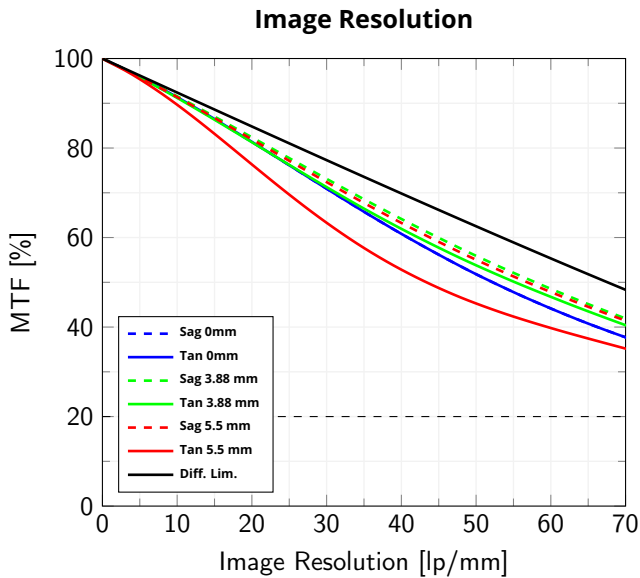

Modulation Transfer Function (MTF) vs. Image Resolution, wavelength range 486 nm - 656 nm. Fields in legend are represented as distance from the center of the image

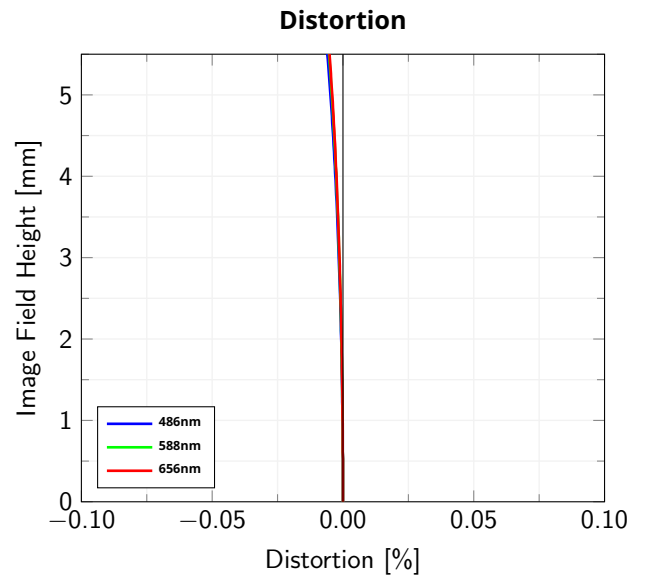
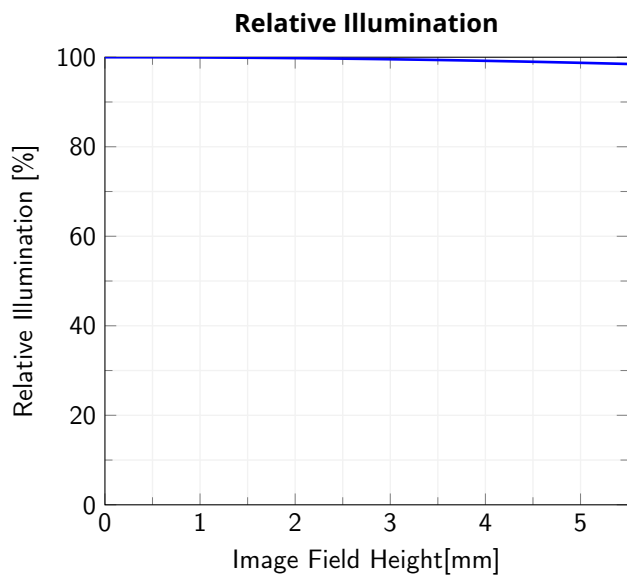
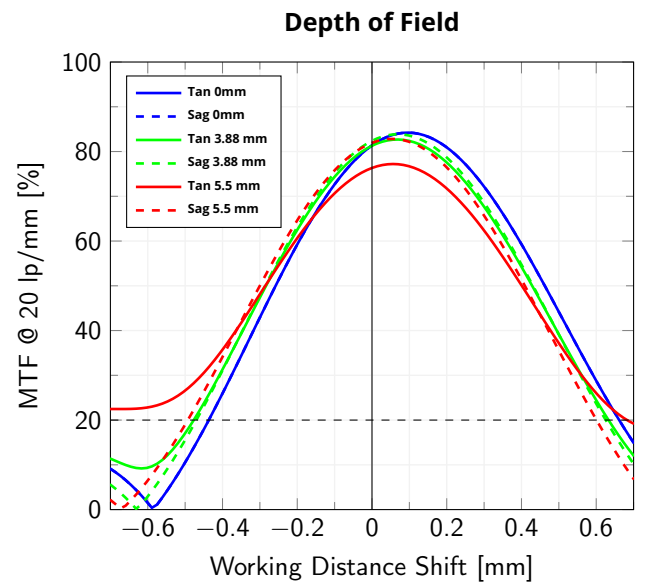

Image Field Height vs. Distortion, from the optical axis to the corner of the image



Relative illumination vs. Image Field Height, from the optical axis to the corner of the created image



Modulation Transfer Function (MTF) @ 20 lp/mm vs. Working Distance Shift from the best focus Working Distance, wavelength range 486 nm - 656 nm. Fields in legend are represented as distance from the center of the image

All product specifications and data are subject to change without notice to improve reliability, functionality, design or other. Photos and pictures are for illustration purposes only. Data are reported by design, actual lens performance may vary due to manufacturing tolerances.

MAGNIFICATION 0.75x, OBJECT TILT 0°

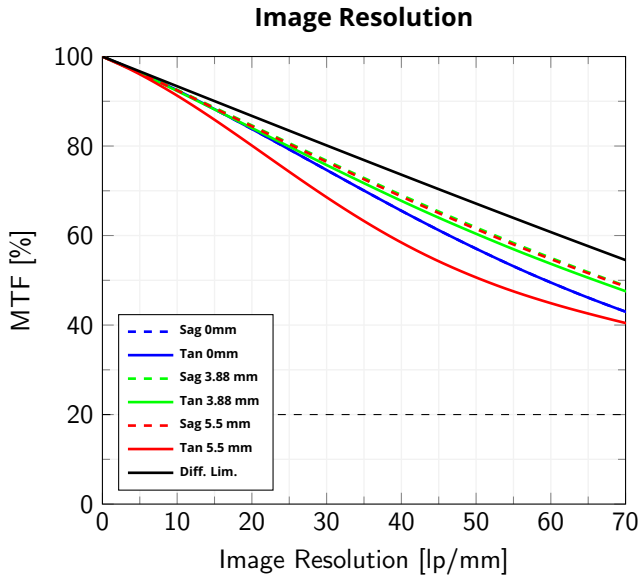

Modulation Transfer Function (MTF) vs. Image Resolution, wavelength range 486 nm - 656 nm. Fields in legend are represented as distance from the center of the image

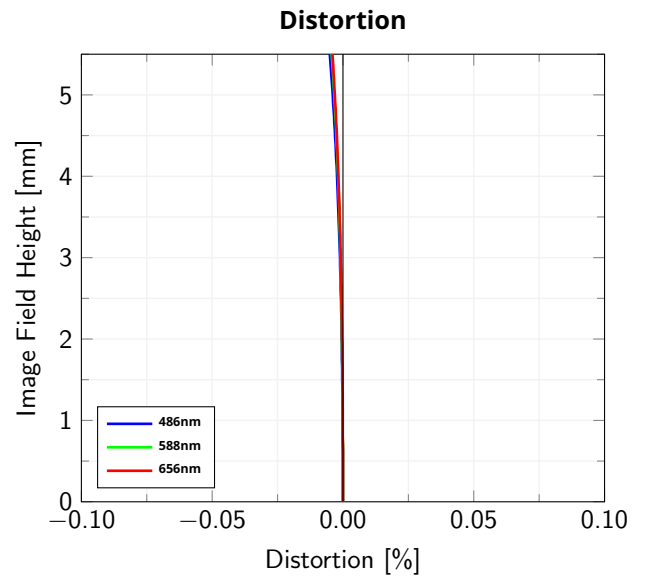
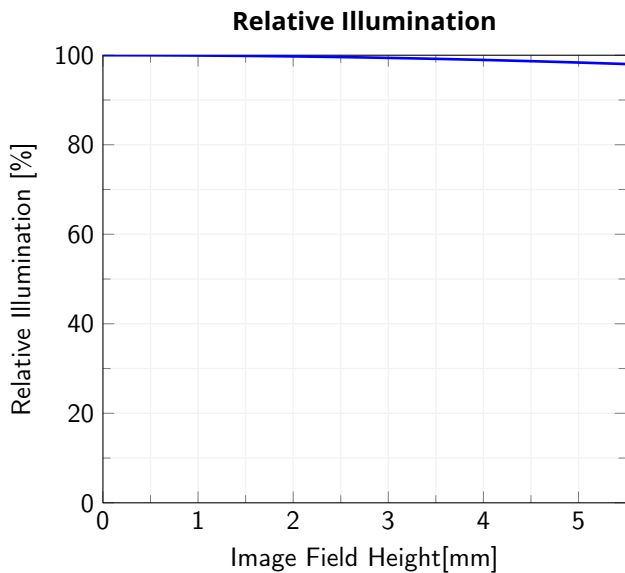
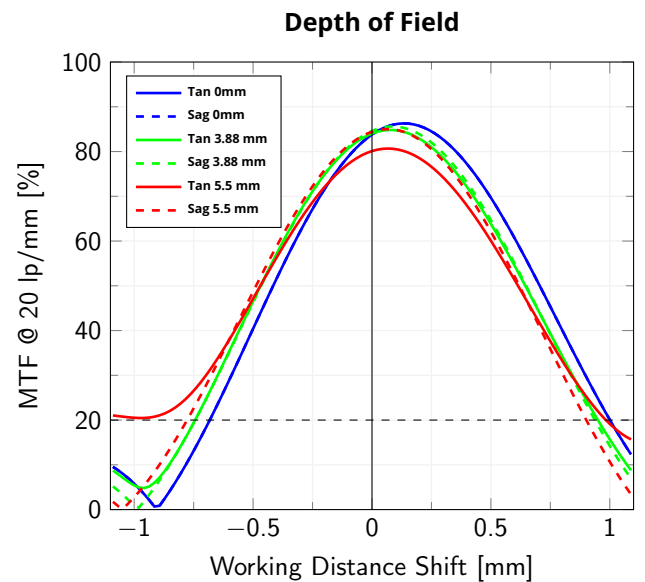

Image Field Height vs. Distortion, from the optical axis to the corner of the image



Relative illumination vs. Image Field Height, from the optical axis to the corner of the created image



Modulation Transfer Function (MTF) @ 20 lp/mm vs. Working Distance Shift from the best focus Working Distance, wavelength range 486 nm - 656 nm. Fields in legend are represented as distance from the center of the image

All product specifications and data are subject to change without notice to improve reliability, functionality, design or other. Photos and pictures are for illustration purposes only. Data are reported by design, actual lens performance may vary due to manufacturing tolerances.

MAGNIFICATION 0.50x, OBJECT TILT 0°

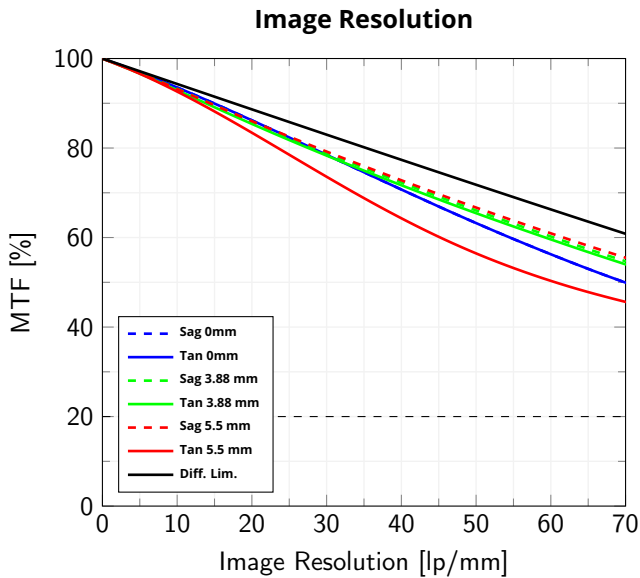

Modulation Transfer Function (MTF) vs. Image Resolution, wavelength range 486 nm - 656 nm. Fields in legend are represented as distance from the center of the image

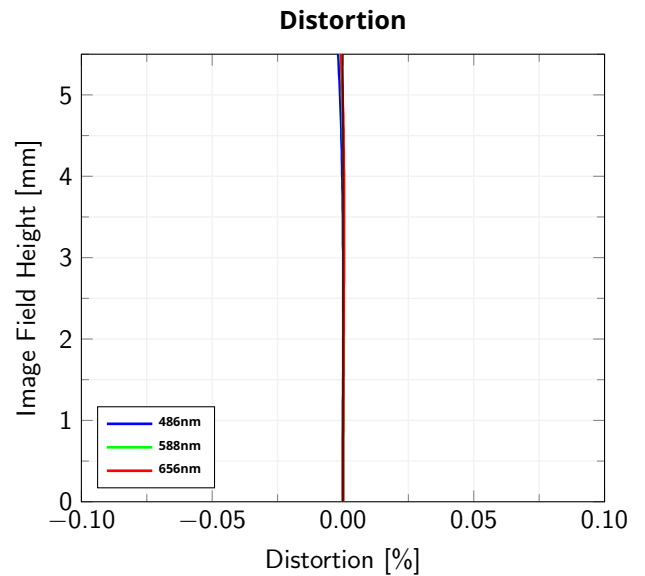
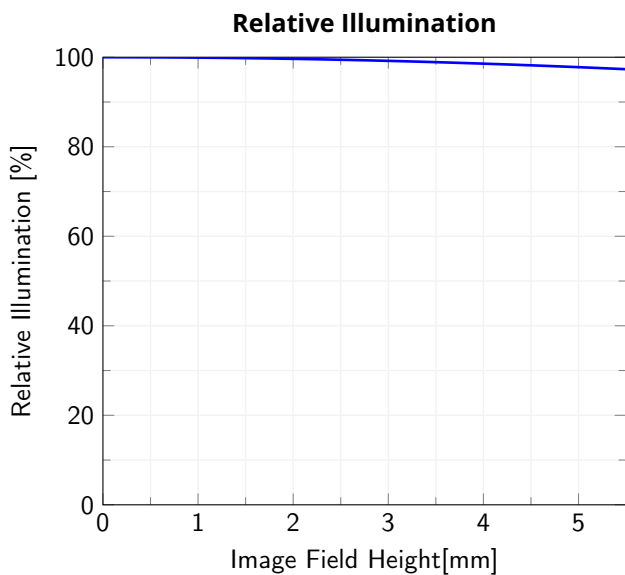
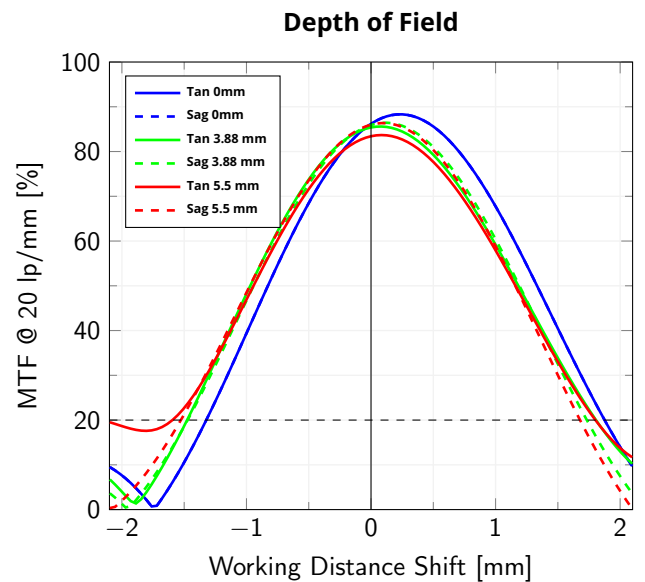

Image Field Height vs. Distortion, from the optical axis to the corner of the image



Relative illumination vs. Image Field Height, from the optical axis to the corner of the created image



Modulation Transfer Function (MTF) @ 20 lp/mm vs. Working Distance Shift from the best focus Working Distance, wavelength range 486 nm - 656 nm. Fields in legend are represented as distance from the center of the image

All product specifications and data are subject to change without notice to improve reliability, functionality, design or other. Photos and pictures are for illustration purposes only. Data are reported by design, actual lens performance may vary due to manufacturing tolerances.

MAGNIFICATION 0.33x, OBJECT TILT 0°

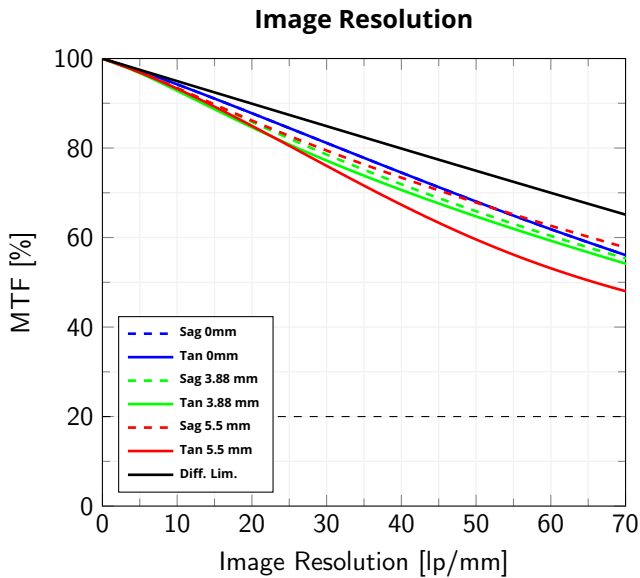

Modulation Transfer Function (MTF) vs. Image Resolution, wavelength range 486 nm - 656 nm. Fields in legend are represented as distance from the center of the image

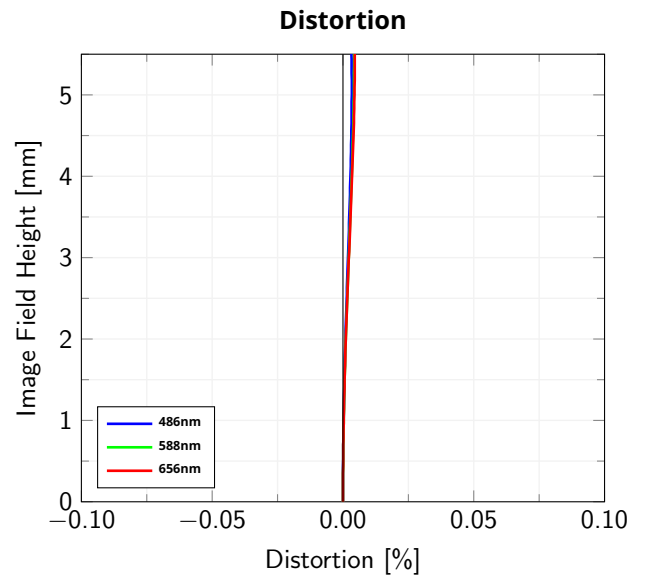
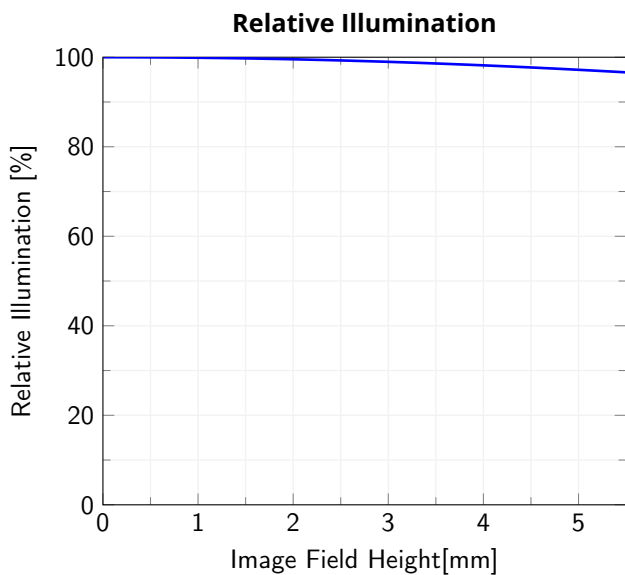
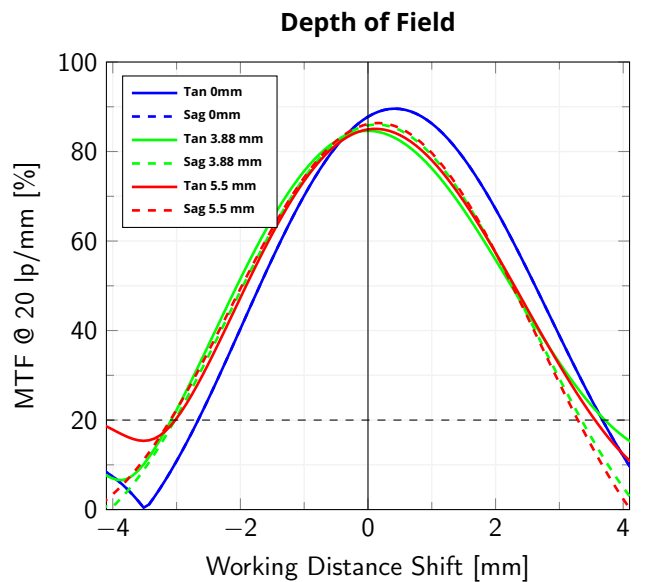

Image Field Height vs. Distortion, from the optical axis to the corner of the image



Relative illumination vs. Image Field Height, from the optical axis to the corner of the created image



Modulation Transfer Function (MTF) @ 20 lp/mm vs. Working Distance Shift from the best focus Working Distance, wavelength range 486 nm - 656 nm. Fields in legend are represented as distance from the center of the image

All product specifications and data are subject to change without notice to improve reliability, functionality, design or other. Photos and pictures are for illustration purposes only. Data are reported by design, actual lens performance may vary due to manufacturing tolerances.

MAGNIFICATION 0.20x, OBJECT TILT 0°

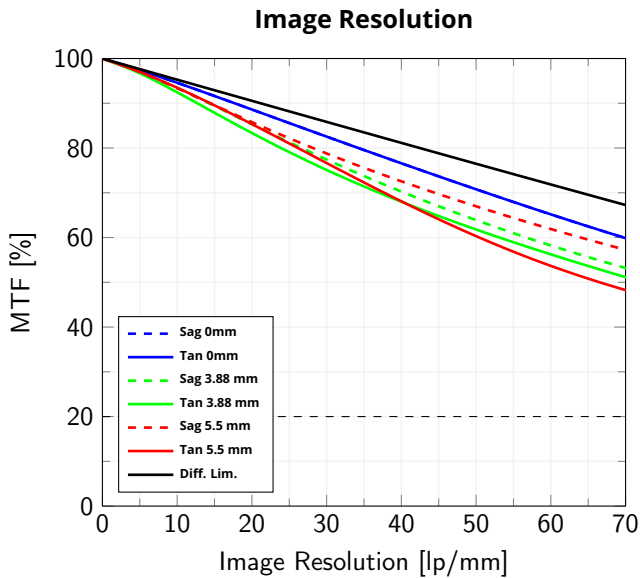

Modulation Transfer Function (MTF) vs. Image Resolution, wavelength range 486 nm - 656 nm. Fields in legend are represented as distance from the center of the image

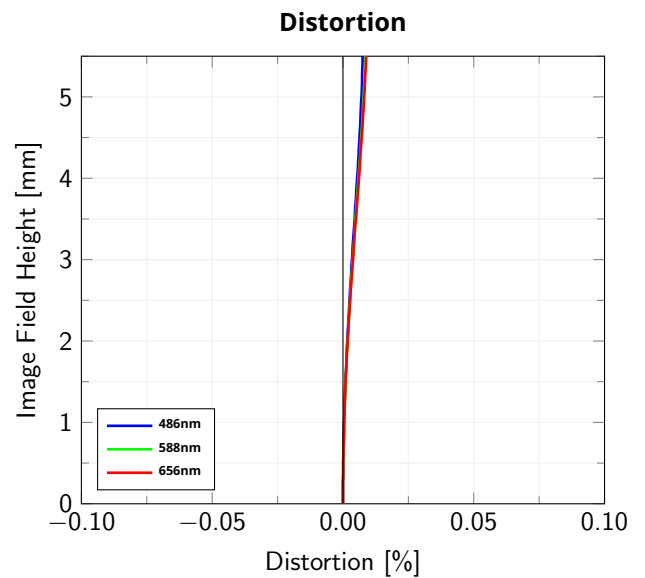
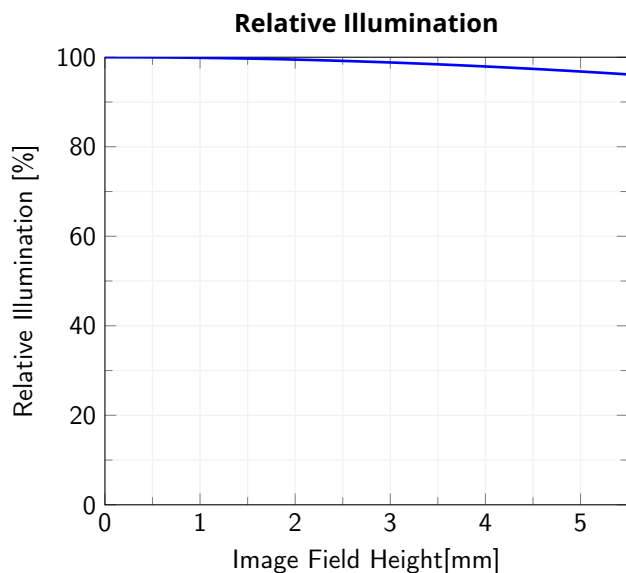
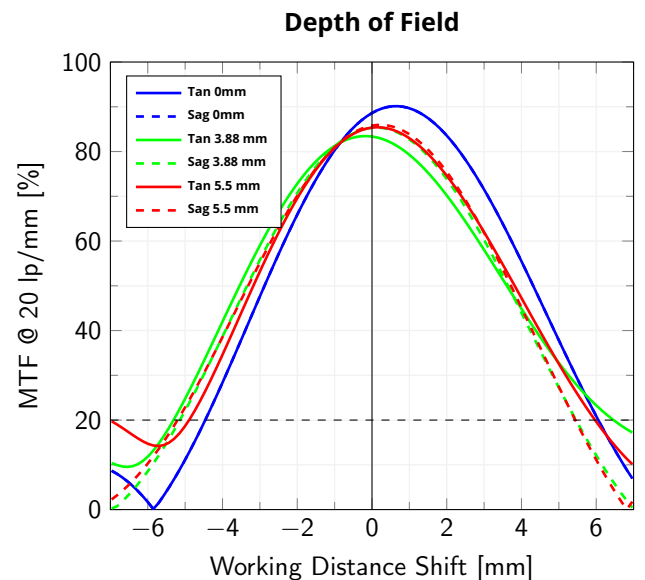

Image Field Height vs. Distortion, from the optical axis to the corner of the image



Relative illumination vs. Image Field Height, from the optical axis to the corner of the created image



Modulation Transfer Function (MTF) @ 20 lp/mm vs. Working Distance Shift from the best focus Working Distance, wavelength range 486 nm - 656 nm. Fields in legend are represented as distance from the center of the image

All product specifications and data are subject to change without notice to improve reliability, functionality, design or other. Photos and pictures are for illustration purposes only. Data are reported by design, actual lens performance may vary due to manufacturing tolerances.